



操作说明书
Instruction Manual

BC 800 R
Battery Charger
320W / 640W

BC 812-20R :	27 150 311
BC 824-10R :	27 150 312
BC 848-05R :	27 150 313
BC 824-20R :	27 150 314
BC 848-10R :	27 150 315
BC 812-40R :	27 150 316

关于

Elektro-Automatik GmbH & Co. KG

Helmholtzstrasse 31-37

41747 Viersen

Germany

电话: 02162 / 37850

传真: 02162 / 16230

网址: www.elektroautomatik.cn邮箱: ea1974@elektroautomatik.cn

© Elektro-Automatik

严禁再版、复印或部分错误地使用该说明书，否则将承担该行为导致的法律后果。



危险电压

警告：本产品输出电压可能上升至危险级别(> 60 VDC)！

产品上所有带电元件必须有外遮盖。输出端的所有操作必须在产品与主电源（电源开关关闭）断开时才能执行，且可只有受过电流危险知识的专业人员执行此类操作。负载与本产品间的任何连接必须有防碰擦装置。连到功率输出端的应用设备必须配置好，并且有保险丝熔断保护，这样可防止使用过程中由于过载或误操作损坏产品或更严重事情发生。



安全说明

- 本电池充电器仅能充符合产品规格的电池或电池组（并联或串联）。如果未激活限制，最大充电电流等同于额定电流！
- 不要连接不可充电电池！
- 连接电池前请先关闭产品！
- 电池连接线的直径必须符合产品的额定输出电流。
- 请避免损坏产品，勿将金属元件插入通风槽，不要阻挡通风槽！
- 必须由专业受训人员执行市电连接。
- 只能选用合适的连线，按照通用安全措施连到市电。
- 避免直接接触太阳光和湿气。
- 电池给电池充电时，可能会从电池内产生大量可燃气体。必须随时保证空气流通良好，禁止在电池周围有明火和火花出现。

	页码
1. 一般信息	5
1.1 简介	5
1.2 目检	5
1.3 供应清单	5
2. 安装	5
2.1 安装	5
2.2 与市电的连接	5
2.3 感测端的连接	5
2.4 直流输出端的连接	5
2.5 模拟接口的连接	5
3. 功能描述	6
3.1 电池类型	6
3.2 充电程序	6
3.2.1 充电特性	6
3.3 电池监控	6
3.4 温度感测	6
3.5 远程感测 (Remote sense)	7
3.6 电源模式 (Power Supply Mode)	7
3.7 过压保护 (OVP)	7
3.8 过温保护 (OT)	7
3.9 错误	7
3.10 远程控制	7
3.11 自动充电模式	7
4. 技术参数	8
4.1 产品尺寸图	9
5. 操作	11
5.1 给产品供电	11
5.2 连接电池	11
5.3 选择电池充电曲线	11
5.4 开始充电	11
5.5 停止充电	11
5.6 用小电流充电	11
5.7 并联待机操作	11
5.8 电源模式 (Power Supply Mode)	11
5.9 模拟接口	12
5.9.1 连接	12
5.9.2 接口引脚分布	12
5.9.3 应用举例	12
5.10 激活自动充电模式	13
6. 其它	13
6.1 重设控制面板	13

1. 一般信息

1.1 简介

BC 800 R系列微处理器控制电池充电器专门设计成墙挂式结构，以空气对流为冷却方式。

本产品专门给不同铅性电池充电。第三阶段，温度补偿充电程序可快速、完整、仔细地给电池充电。

而且，产品还有一电源模式，其输出电压变得可调。

电源输出端有反接保护，短路保护和过载保护。为了保护负载，产品还有过压保护（OVP）功能。出现过温（OT）时，电源输出关闭，直至温度冷却，又自动打开。

1.2 目检

收到本产品后，请检查是否有外观受损痕迹。如有，请不要操作本产品，应立即联系您的供应商。

1.3 更换内部保险丝

提示：这不适用于BC 812-40 R产品，因为该产品的保险丝位于前面保险丝座上。

电源保险丝位于产品里面。打开产品前，先将它完全与市电断开。

必须是接受过危险知识和安全规则训练的技术人员才可在打开的产品上操作。

要替换保险丝，需先松开前盖螺丝，小心地取下盖。保险丝就在主板上，位于左手边。

1.4 供应清单

- 1 x 电池充电器
- 1 x 印刷版使用说明书
- 1 x 电源插座（仅针对外壳类别1）
- 1 x 温度传感器LM335Z (10mV/K)
- 1 x 组装套件（仅针对BC 812-40 R产品）

2. 安装

2.1 安装

本产品设计成墙挂式结构。安装时需按空气顺着通风槽流出的方式安装。注意产品的上方和下方应保留一定空间（至少15cm），以保证足够的冷却效果。

也可见第9页图。

2.2 与市电的连接

本系列所有型号都具有正向PFC（功率因素校正）和宽范围输入电压。可在90V至264VAC输入电压，以及45Hz至65Hz频率下工作。

按照前板丝印将电源线连到3位端子上（型号为：Phoenix Combicon GMSTB 2,5/3-ST-7,62）。仅受训技术人员方可执行。必须使用适当直径的电源线，因为本产品无电源开关。电源输入端由一标准的5x20mm保险丝保护，它装于产品内部。

2.3 直流输出端与感测端的连接

直流输出端与远程感测输入端位于产品前面。除BC 812-40 R产品外，其它型号都采用同类型的卡紧型端子，适合安装直径为0.08mm² (28 AWG)至4mm² (12 AWG)的连线。如果可以，线尾请装上线套。

连线夹紧步骤：

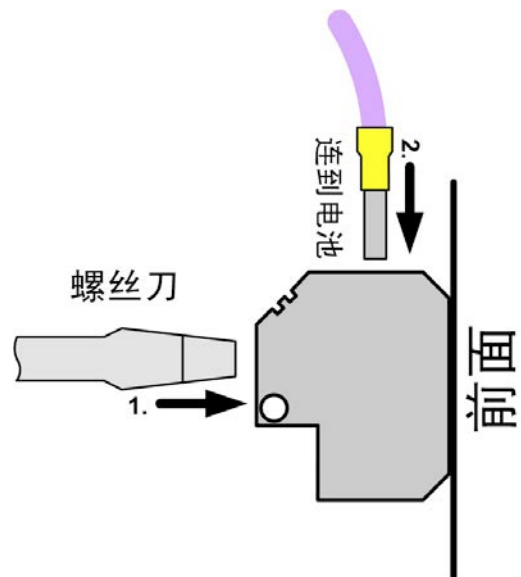

而BC 812-40 R产品，则经由螺丝端子连到电池上。

2.4 模拟接口的连接

见章节„5.9 模拟接口“。

3. 功能描述

3.1 电池类型

本电池充电器可用来充不同类型的铅性电池，如铅酸，GEL或AGM类型。任何类型的充电都按照三个阶段，以及温度补偿（仅当连接了温度传感器时）充电程序进行。按下前板按钮可选择电池类型。相关的充电曲线图主要不同在于每节电池的电压（见右表）。

3.2 充电程序

注意！不良电池 ($U_{\text{BatAct}} = < 0.4 \times U_{\text{BatNom}}$) 不能充电！

充电程序按照I-U-U特性进行。

充电程序的第一步为**预充**，并以较小的输出电流 ($0.1 \times I_{\text{Nom}}$) 充电。预充对过放的电池非常有效，以 $U_{\text{BatAct}} = > 0.2 \times U_{\text{BatNom}}$ 充电，使之能修复和重复给电池充电。一旦输出电压上升至，或者最大限度地充了**30分钟**后，充电程序将转为**普通充**。预充和普通充都通过交通灯型的红色指示灯指示出来。

在普通充电阶段，电池以全电流 I_{Nom} 充电（或30%的输出电流 $I\text{-Limit}$ ）。

恒流充完成后，或进行了最长**6个小时**的充电后，充电程序转为**快充**（黄色灯亮）。

快充时电压减少，一旦充电电流为 I_{Nom} 的5%，或快充时间超过普通充的**1.5倍**，充电将进入**涓充**。

如果充电电流在 I_{Nom} 的5%以下，通过绿色状态灯，指示电池已充满。

涓充时，以涓充电压无限期地给电池充电，直至出错或断电而停止或中断。

建议在**快充**和**涓充**阶段使用温度补偿，可防止电池产生气体。

提示：可激活30% $I\text{-Limit}$ ，手动减少输出电流。激活该功能，需按住“Charging Profiles”按钮长达3s。

$I\text{-Limit}$ 对以小电流给小电池充电时非常有用。

3.2.1 充电特性

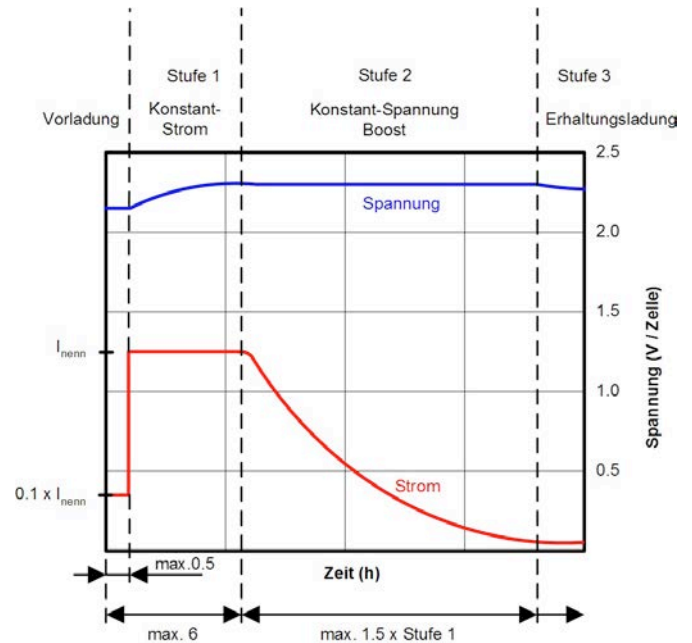

3.3 电池监控

单个电池或一组电池都可接到产品前板标有“Battery”的特定端子上。本产品能对输出端的反极性和错误电池电压进行监控。若电池极性反接到充电器上，或者电池电压太低或太高，都不会启动充电程序。

注意！仅能连接与产品额定充电电压相符的电池。否则可能会损坏电池和/或产品。

3.4 温度感测

我们建议给电池充电时，启动温度补偿功能，以免产品产生危险气体。

未连接温度传感器时，则以对应25°C环境温度的恒定电压给电池充电。连接温度传感器时，将它直接接到模拟接口的第1和6脚，然后放在电池周围或直接附在电池上。充电开始时即开始检测和使用。如果测量到的温度低于高于+50°C，则停止充电。待温度下降至+45°C后，继续自动充电。该功能仅在安装有温度传感器时才工作。只要电池过温错误出现，错误灯就一直闪烁。

如果温度低于-15°C，则停止温度补偿。如果在充电过程中取下或损坏传感器，产品则按照25°C的充电电压继续充电。

为了让用户发现温度相关的错误，即使该温度值已回到正常范围，LED灯也一直闪烁。再次开始充电或转为电源模式会清除错误，如果温度正常，LED不再闪烁。

可使用LM335或类似温度传感器，充电电压的温度补偿为每节电池4mV/°C。

3.5 远程感测 (Remote sense)

要补偿负载线上的压降，产品前板还具有—远程感测输入端。按正确极性连线到此，感测电池的电压。远程感测端可补偿多达2V的电压。

不用该感测输入端时，就让它空闲着，不用连跳线到输出端。

感测线的直径非关键条件。

3.6 电源模式 (Power Supply Mode)

如果用“充电配置文档”按钮选择了“Power Supply Mode”，本产品就可当电源用。在该模式下，用电位器可在限定范围内（见„4. 技术参数“）调节输出电压。它可以按恒压或恒流模式操作（U-I特性），并通过前板的绿色或红色LED灯指示出来。。

该模式适合并联待机操作，也见„5.7 并联待机操作“。

3.7 过压保护 (OVP)

本系列所有型号都有过压保护电路。如遇过压错误，不论是因内部故障或外部原因引起的，电源输出关闭，且以“Error” LED灯闪烁和模拟接口的9脚指示出该错误。OV过压错误消失后，输出再次打开，并开始充电。

3.8 过温保护 (OT)

本系列所有型号还有内温监控功能。如遇过热，电源输出暂时关闭，直至冷却后又自动打开。

充电仅被打断，并未停止。以闪烁的“Error” LED灯和模拟接口的9脚指示出来该状态。

3.9 错误

任何错误都由闪烁的“Error” LED灯指示出来。下面为LED灯提示的基本错误：

- 过压 (OVP)
- 过温 (OT)
- 连接到电压源的电池或其他负载的极性连接错误

OVP和OT错误也在模拟接口上指示出来。

在电池充电器模式，即，非电源模式，将提示下列额外的错误信号：

- 连接电池的电压太低或太高
- 温度传感器失效（连线断或其它）

3.10 远程控制

本系列所有型号的前板上都配有一12脚模拟端口。可通过它监控产品状态，以及远程启动/停止充电程序。也可见章节5.9以及之后的描述。

3.11 自动充电模式

可以激活这个额外的操作模式，一旦产品接上市电或接上电池后，自动给电池充电。详情请看„5.10 激活自动充电模式“。

4. 技术参数

	BC 812-20R	BC 824-10R	BC 848-05R	BC 812-40R	BC 824-20R	BC 848-10R
电源输入						
输入电压	90...264V	90...264V	90...264V	90...264V	90...264V	90...264V
输入频率	45...65Hz	45...65Hz	45...65Hz	45...65Hz	45...65Hz	45...65Hz
功率因数	>0.99	>0.99	>0.99	>0.99	>0.99	>0.99
230V时输入电流	1.6A	1.6A	1.6A	3.4A	3.2A	3.2A
输入保险丝	M6.3A	M6.3A	M6.3A	T10A	T10A	T10A
输出 - 电压						
电池电压 U_{Bat}	12V	24V	48V	12V	24V	48V
可调范围	10...15V	20...30V	40...60V	10...15V	20...30V	40...60V
带载10...90%时的稳定度	<0.05%	<0.05%	<0.05%	<0.05%	<0.05%	<0.05%
市电波动范围在 $\pm 10\% \Delta U_{IN}$ 时的稳定度	<0.02%	<0.02%	<0.02%	<0.02%	<0.02%	<0.02%
纹波	<40mV _{pp}	<100mV _{pp}	<150mV _{pp}	<10mV _{pp}	<100mV _{pp}	<150mV _{pp}
带载10-100%的调整	<2ms	<2ms	<2ms	<2ms	<2ms	<2ms
输出 - 电流						
额定电流	20A	10A	5A	40A	20A	10A
带载0...100% ΔU_{OUT} 时的稳定度	<0.15%	<0.15%	<0.15%	<0.15%	<0.15%	<0.15%
市电波动范围在 $\pm 10\% \Delta U_{IN}$ 时的稳定度	<0.05%	<0.05%	<0.05%	<0.05%	<0.05%	<0.05%
纹波	<60mA _{pp}	<35mA _{pp}	<12mA _{pp}	<19mA _{pp}	<65mA _{pp}	<25mA _{pp}
输出 - 功率						
额定功率	300W	300W	300W	600W	600W	600W
其它						
工作温度	0...50° C	0...50° C	0...50° C	0...50° C	0...50° C	0...50° C
储存温度	-20...70° C	-20...70° C	-20...70° C	-20...70° C	-20...70° C	-20...70° C
相对湿度	<80%	<80%	<80%	<80%	<80%	<80%
尺寸 (WxHxD)	218x83x163mm	218x83x163mm	218x83x163mm	90x360x240mm	218x83x163mm	218x83x163mm
重量	2.2kg	2.2kg	2.2kg	6.5kg	2.2kg	2.2kg
产品编号	27150311	27150312	27150313	27150316	27150314	27150315
安全标准	EN 60950					
EMC标准	EN 61326, EN 55022 等级 B					
过压等级	等级 II					
保护等级	等级 I					

4.1 产品尺寸图

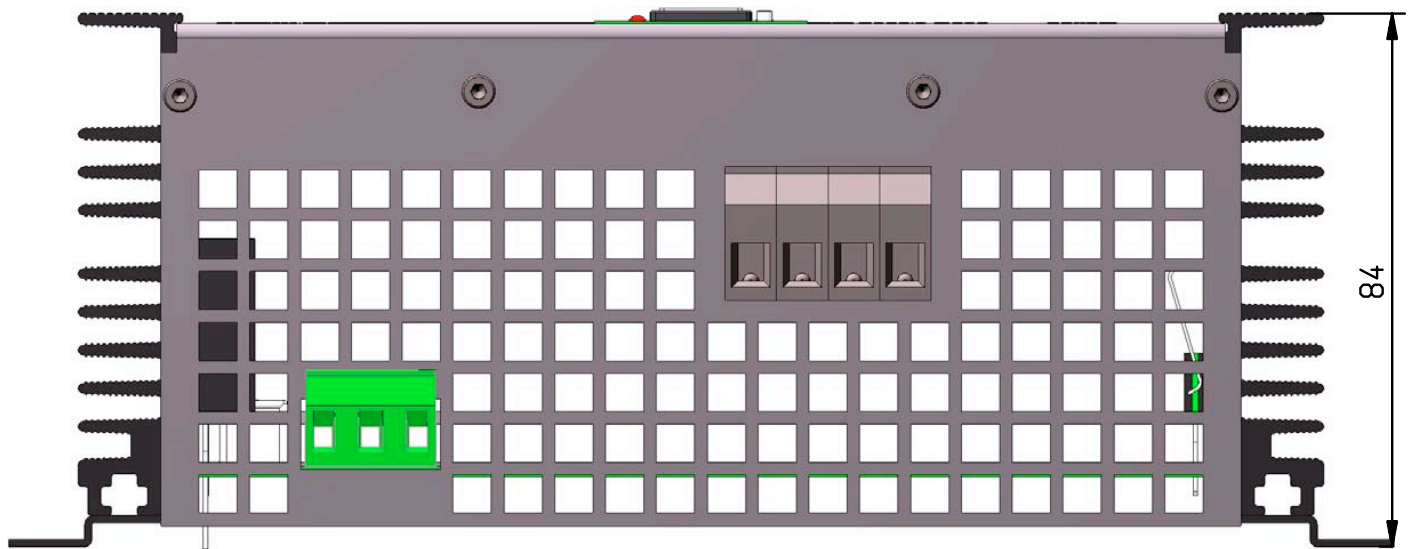
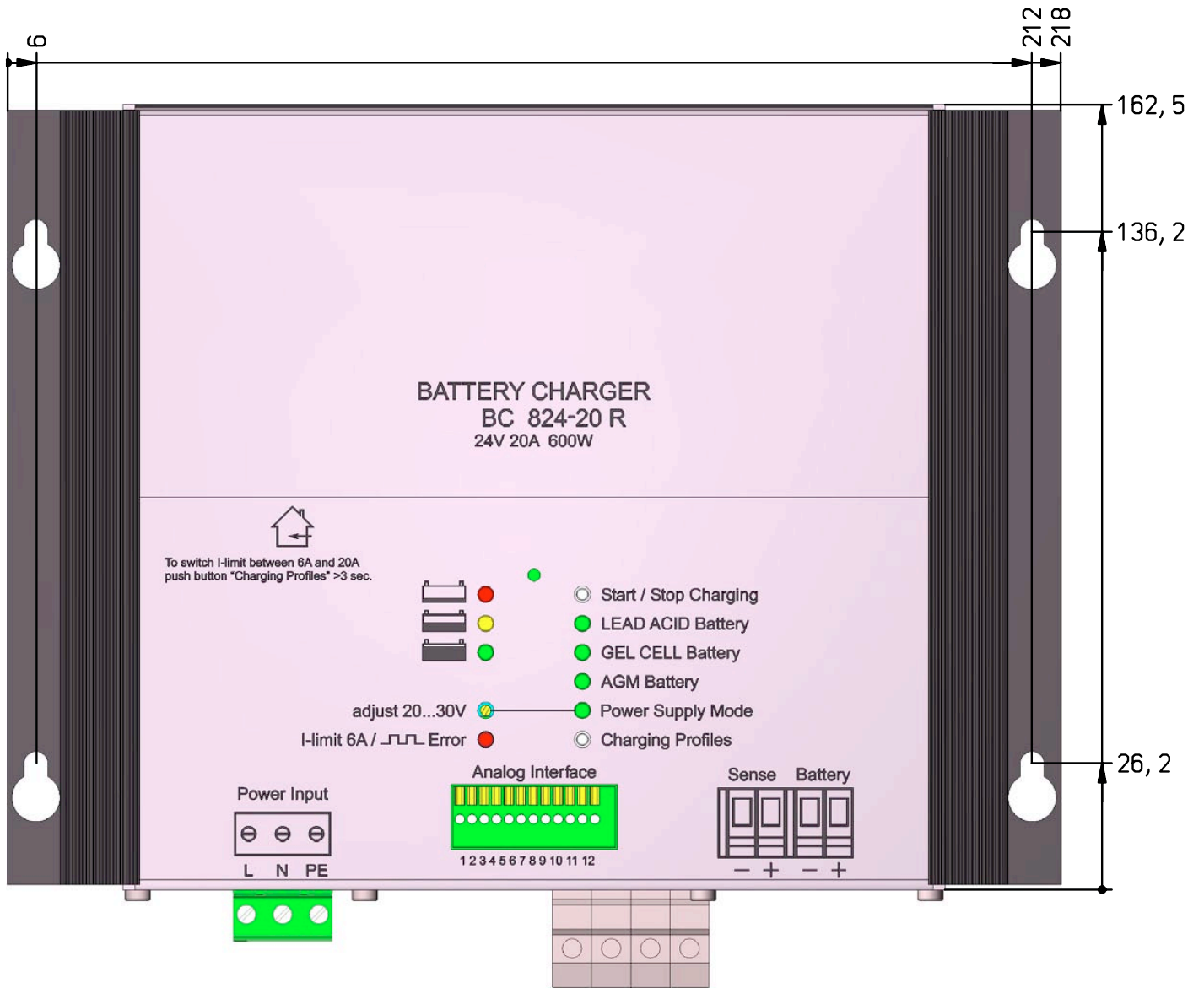

外壳类别 1: 20A以下产品型号

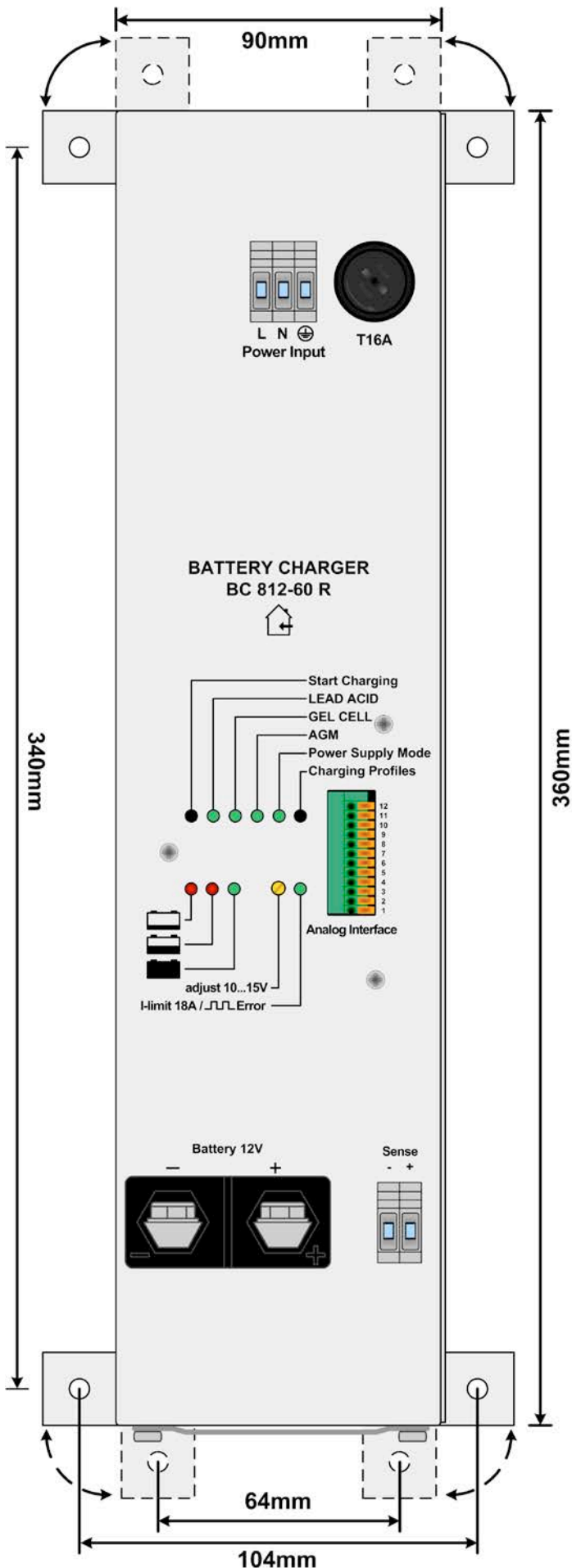

外壳类别 2, 为BC 812-40 R外壳

5. 操作

5.1 给产品供电

产品与市电连接后, 不会形成电源开关的功能, 而是立即工作。

关闭产品后将存储最后状态(选定模式, 输出条件), 以便下次启动时自动恢复。因此在遇断电等这样的中断并恢复后, 可继续工作。意思是, 它会继续充电, 只要充电条件未改变(未出现电池电压或极性错误, 电池温度错误, 电池未连接)。

5.2 连接电池

本电池充电器只允许给符合产品输出电压的电池充电。如果激活“**I-Limit**”, 充电电流为最大值或 I_{Nenn} 的30%。加上温度补偿电压, 最大充电电压约为2.43V/节(根据电池型号)。

电池连线的直径必须按照充电器的额定电流而选用。

注意! 连接或断开电池前, 必须检查是否已停止充电。此时印在前板上的电池水平符号旁的LED灯都不亮。

5.3 选择电池充电曲线

充电前选择电池曲线图, 需先关闭输出。用“**Charging Profiles**”按钮选择三个充电曲线的其中一个, 所有曲线图都是针对**铅性电池**。LED灯指示所选电池类型。

选定的充电曲线考虑了特定电池每节的电压, 这是由电池生产商指定:

	普通充	快充	涓充
铅酸电池	2V/节	2.38V/节	2.28V/节
Gel电池	2V/节	2.40V/节	2.28V/节
AGM电池	2V/节	2.43V/节	2.28V/节

5.4 开始充电

按下“**Start / Stop Charging**”按钮, 或使用模拟接口的引脚8可启动充电。下面错误现象会阻止充电程序的启动:

- 电池没连接
- 电池电压太低 (LED闪烁)
- 电池电压太高 (LED闪烁)
- 电池温度太高 (LED闪烁) (仅当温度传感器连接时)
- 电池反接

按照选定电池曲线和按照“**充电程序**”章节的充电特性图形描述充电。当前激活的充电阶段以前板丝印的电池充满水平符号对应的LED灯指示出来。

充电程序也由模拟接口上的“**Charging**”信号指示。

提示: 手动停止充电后需要等约30s以上方可再次开始充电。长时间断电或者手动关闭后也适用该规则。短时间断电(<5s)造成充电程序暂停, 可由产品本身进行补偿。

5.5 停止充电

“Start / Stop Charging”按钮还可用来立刻停止任何阶段的充电。然后关闭输出，LED不再亮。

连接或断开电池前，必须停止充电！

5.6 用小电流充电

小容量的电池通过激活“I-Limit”功能，每充电阶段都以小电流（正常电流的30%）充电。

减少后的最大充电电流以“I-limit xA”（“Error”灯旁边）注明在前板上。“I-Limit 30%”灯指示已激活的限流功能长期有效（只要未出现错误）。

按住“charging profiles”按钮长达3秒，可随时激活该功能。

5.7 并联待机操作

提示：只有选择了“Power Supply Mode”后，才适合进行并联待机操作。

在电源模式下（见章节5.8），本产品可进行并联待机操作，也可跟另外一处于充电模式的充电器一起操作。从而产生UPS的工作特性。

5.8 电源模式 (Power Supply Mode)

本充电器可当电源用，但其输出电压可调范围被限定。要选择电源（Power Supply Mode）模式，需在输出关闭时，按下“Charging Profiles”按钮。

按下“Start / Stop Charging”按钮可打开或关闭电源输出。

输出打开时，绿色状态灯指示恒压（CV）操作，或红色状态灯指示恒流（CC）操作。如下图：

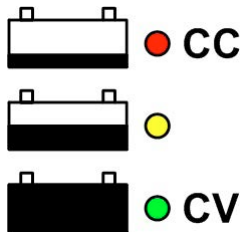

两种运行模式根据输出端的电压/电流状态而定。

输出电流被限为产品额定电流，且不可调。

若想用电位器在指定范围内调节输出电压，需先打开输出。

只有输出关闭时方可连接负载。负载线的直径必须符合产品的额定电流。

提示：在电源模式下，产品也能通过闪烁的错误灯指示出电池被反接。

提示：可手动转换的电流极限功能I-Limit可将输出电流减小至30%。

5.9 模拟接口

模拟接口可远程监控产品的输出值（电压和电流）和状态（错误）。监控输出端的0...10V电压对应0...100%的额定值。

温度传感器也可接到模拟接口上。适合夹20 - 26 AWG的线，线头须剥皮至少10mm。

见上页表格关于模拟接口的引脚分布和级别描述。

注意！千万不要连接任何事物至11和12引脚。

要远程启动或停止充电程序，需先将7引脚下拉至low，将产品转至远程控制。也可见下图示例。

提示：使用“Remote”或“REM-SB”数字脚时，需用到一低阻接触件（如开关，继电器，或开集三极管）。PLC类控制设备的数字输出脚可能不够用，请先参阅您控制设备的技术文档。

5.9.1 连接

产品顶部的12针模拟接口也采用按压夹紧型端子。适合安装0.1mm² (26 AWG)至0.5mm² (20 AWG)直径的连接线。如果可以，线尾请套上线套。

连线夹紧步骤：

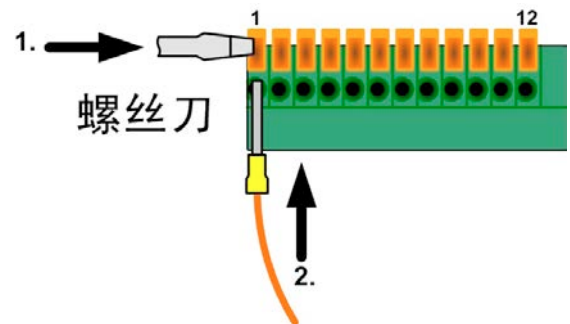

5.9.2 接口引脚分布

引脚	名称	类型 ¹⁾	描述	电平	电气参数
1	温度传感器	A0	温度传感器	LM 335	10mV/°K
2	涓流 / 电池满	A0	涓流/电池已满	充电完成 = High ($U_{High} > 4V$), 其它 = Low ($U_{Low} < 1V$)	$U_{max} = 30V$, $I_{max} = -20mA$
3	充电	A0	充电激活	充电中 = High ($U_{High} > 4V$), 其它 = Low ($U_{Low} < 1V$)	准集电极上拉至 V_{CC} ²⁾
4	VMON	A0	实际值: 电压	0...10V 相当于 0...100% 的 U_{Nom}	$I_{max} = +2mA$ 时, 精确度为 0.1%, 对 AGND 有短路保护
5	CMON	A0	实际值: 电流	0...10V 相当于 0...100% 的 I_{Nom}	
6	AGND		模拟信号地		CMON, VMON 用
7	远程	AI	远程控制激活	外部 = Low ($U_{Low} < 1V$), 内部 = High ($U_{High} > 4V$)	
8	启动/停止	AI	电源模式: 电源输出关闭 电池模式: 启动/停止充电	关 / 启动 = Low ($U_{Low} < 1V$), 开 / 停止 = High ($U_{High} > 4V$)	$U_{max} = 30V$ $I_{max} = -1mA@5V$
9	OT / OVP	A0	过温 OT / 过压 OVP	Low = 无错误 ($U_{Low} < 1V$), High = 出错 ($U_{High} > 4V$)	$U_{max} = 30V$, $I_{max} = -20mA$, 准集电极上拉至 V_{CC} ²⁾
10	DGND		数字信号地		用来控制和监控信号
11	保留	X	不能连		
12	保留	X	不能连		

¹⁾ AO = 模拟输出, AI = 模拟输入

²⁾ 12V...15V

5.9.3 应用举例

I. 开始/停止充电 (输出开/关)

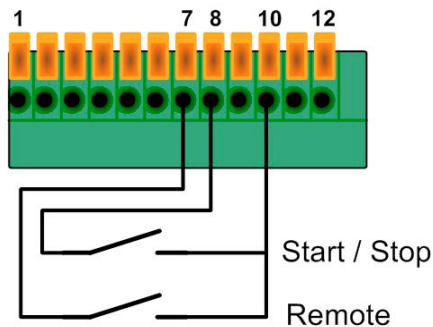

远程启动充电前, 需将产品设为远程控制 (引脚7)。在电池充电模式下, 该引脚可开始或停止充电。

在“Power Supply Mode”下, 引脚8关闭电源输出, 以及再次打开。在该模式下, 无论远程是否激活, 都可使用输出, 像紧急关闭开关一样。

参考脚为数字地 (DGND)。

警告! 如果“Start/Stop”引脚在转至远程控制时已下拉, 则立即开始充电。

II. 监控产品状态流

输出脚为准集电极输出脚, 装有一10k上拉电阻连至 V_{CC} 。最大输入电压不能超过30V, 最大输入电流不能超过20mA。

通过该功能, 在不需放大的情况下, 用继电器或LED灯指示状态。

注意: 当指示特定信号时该引脚级别为HIGH。用来控制继电器或LED灯时可能需进行相反的设置。

参考脚为数字地 (DGND)。

III. 监控电压和电

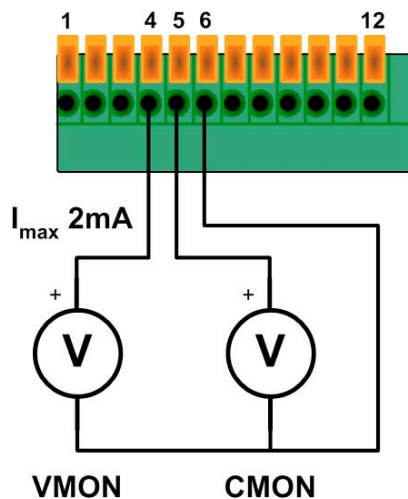

模拟监控输出脚输出0...10V电压, 对应额定电压的0...100%。

参考脚为模拟地 (AGND)。

IV. 温度感测输入脚

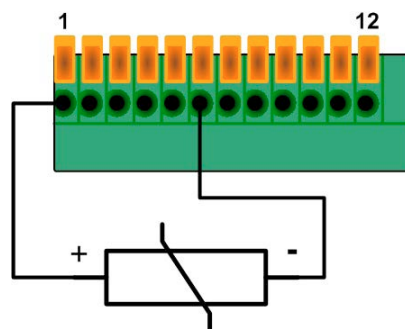

温度传感器

底视图

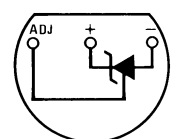

(ADJ引脚不用)

温度传感器放置于电池周围, 或直接贴在其表面, 它将根据电池环境温度来改变充电电压。

重点是仅能使用10mV/K的传感器。允许的温度范围为-15°C...50°C。

使用的传感器为LM335，引脚分布见上面所示。一定要根据连线图按正确极性连接。

5. 10 激活自动充电模式

*提示：自动充电模式需要先将产品转换到远程控制模式。在远程控制模式下，不能进行任何手动控制。意思是，若想使用限流功能“*I-Limit*”，必须预先激活它。且要预先选择电池类型（*LEAD ACID*等）。*

自动充电方式

a) 一旦接通市电，且接上电池，并无错误出现，即自动开始充电

b) 一旦将电池接到运行中的充电器上，且无错误出现，即自动开始充电

为了激活该模式，需在模拟接口上加跳线，如果想用手动钳开关装置的话，也可用开关代替。用跳线时，不能手动终止充电程序。

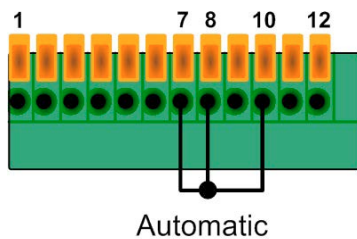

如果完成充电（绿灯亮），可给下一个电池充电。

注意！如果电池端同时接有负载，可能会从充电器处吸取电流。如果吸收的电流很大，充电器会认为电池是空的，此时它会进入快充阶段或预充模式，从而改变输出电压。

6. 其它

6. 1 重设控制面板

在很少情况下，产品对手动控制不响应，此时可重设控制。产品启动后，按住“Charging profiles”按钮即完成。该动作会重设下列功能：

- 输出关闭
- 选择电源模式

About

Elektro-Automatik GmbH & Co. KG

Helmholtzstrasse 31-37

41747 Viersen

Germany

Phone: +49 2162 / 37850

Fax: +49 2162 / 16230

Web: www.elektroautomatik.de

Mail: ea1974@elektroautomatik.de

© Elektro-Automatik

Reprint, duplication or partly, wrong use of this user instruction manual are prohibited and might be followed by legal consequences.



Dangerous voltage

Caution: The output voltage can rise to dangerous levels (> 60 VDC)!

All live parts have to be covered. Make sure, that the cover is installed over the output terminals before taking the unit into operation. All actions at the output terminals have to be done while the unit is switched off from the mains (mains switch OFF) and may only be executed by personnel which is instructed about the hazards of electrical current. Any connection between the load and the unit (at the output terminals) have to be scoop-proof. Applications connected to the power output must be configured and fused in a way that prevents the use of these to cause a damage or worse to the unit by overload or malfunction.



Safety instructions

- The battery chargers must only charge batteries or battery chains (parallel or series connected) that match the device specifications. The maximum charging is identical to the nominal current, if the limitation is not activated!
- Do not connect batteries that are not rechargeable!
- Switch device off before connecting batteries!
- The cross section of the battery cable has to match the nominal current of the device.
- Avoid any damage to the device, do not insert metal parts through the slots, do not obstruct the slots!
- Mains connection must only be done by trained technical personnel.
- Mains connection only with appropriate leads and under adherence of common safety measures.
- Avoid direct sunlight and humidity.
- When charging batteries, highly flammable gas can emerge from the batteries. Always take care for sufficient ventilation and strictly avoid open fire and spark formation in the proximity of the batteries.

	Page
1. General	17
1.1 Introduction	17
1.2 Visual check	17
1.3 Scope of delivery	17
2. Installation	17
2.1 Mounting	17
2.2 Mains connection	17
2.3 Sense connection	17
2.4 DC output connection	17
2.5 Analogue interface connection	17
3. Functional description	18
3.1 Battery types	18
3.2 Charging procedure	18
3.2.1 Charging characteristics	18
3.3 Battery supervision	18
3.4 Temperature sensor	18
3.5 Remote sense	19
3.6 Power supply mode	19
3.7 Overvoltage protection (OVP)	19
3.8 Overtemperature (OT)	19
3.9 Errors	19
3.10 Remote control	19
3.11 Automatic charging mode	19
4. Technical specifications	20
4.1 Dimensional drawings	21
5. Handling	23
5.1 Powering the device	23
5.2 Connecting batteries	23
5.3 Selecting a battery profile	23
5.4 Start charging	23
5.5 Stop charging	23
5.6 Charging with reduced current	23
5.7 Parallel standby operation	24
5.8 Power Supply Mode	24
5.9 The analogue interface	24
5.9.1 Connection	24
5.9.2 Pin assignment	25
5.9.3 Example applications	25
5.10 Activate automatic charging mode	26
6. Miscellaneous	26
6.1 Resetting the control panel	26

1. General

1.1 Introduction

The microcontroller controlled battery chargers of the BC 800 R series are designed for wall mount and work with an airflow based cooling.

They are intended to charge different type of lead batteries. The three-stage, temperature compensating charging procedure allows fast, complete and careful charging of the batteries.

Furthermore, the devices feature a power supply mode where the output voltage becomes adjustable.

The power output is protected against false polarity connection, is short-circuit-proof and overload-proof. For protection of the loads, the devices also feature an overvoltage protection (OVP). At an overtemperature (OT) event, the power output will be switched off until the unit has cooled down and automatically switch on again.

1.2 Visual check

After receipt, the unit has to be checked for signs of physical damage. If any damage is found, the unit may not be operated. Also contact your dealer immediately.

1.3 Replacing the internal fuse

Note: does not apply to model BC 812-40 R, because here the fuse is located in a fuse holder on the front.

The main fuse is located inside the device. Before opening the device, completely disconnect it from mains.

Working on the open device must only be done by trained technical personnel which is instructed about the dangers and safety regulations.

In order to replace the fuse, unscrew the front cover plate and remove it precautiously. The fuse is located on the main PCB, on the left-hand side.

1.4 Scope of delivery

- 1 x Battery charger unit
- 1 x Printed user manual
- 1 x Mains connector (only with housing type 1)
- 1 x Temperature sensor LM335Z (10mV/K)
- 1 x Mounting kit (with model BC 812-40 R only)

2. Installation

2.1 Mounting

The device is designed for wall mount. It is required to mount it in a way that allows unimpeded air flow through the ventilation slots. Take care for plenty of space (at least 15cm) below and above the device in order to ensure proper cooling.

2.2 Mains connection

All models are equipped with an active PFC (power factor correction) and a wide range input. It can be operated at AC input voltages from 90V to 264V and mains frequencies of 45Hz up to 65Hz.

The connection is done with the included 3-pole plug (Phoenix Combicon GMSTB 2,5/3-ST-7,62) according to the print on the front plate. It must only be carried out by trained technical personnel. Main focus lies on an appropriate cross section of the mains lead, as well as the fact that the device does not feature a power switch. The mains input is fused by a standard 5x20mm fuse which is located inside the unit.

2.3 DC output and sense connection

The DC output for the battery connection and the remote sense inputs are located on the front. Except for model BC 812-40 R, these are all of the same type (press & clamp). Cable cross section goes from 0.08mm² (28 AWG) to 4mm² (12 AWG). If possible, use cable end sleeves.

Clamping procedure:

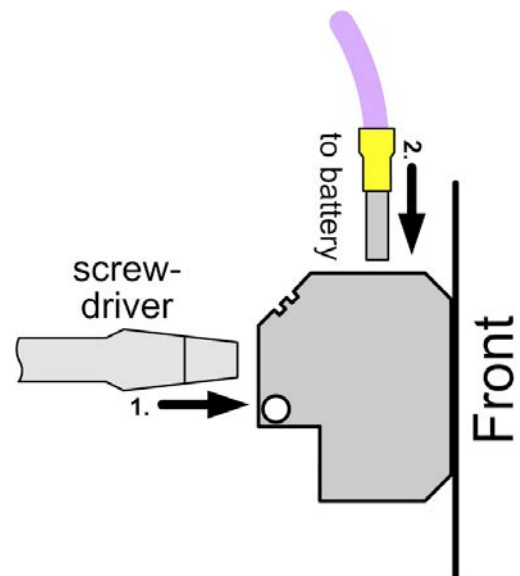

With model BC 812-40 R, the battery is connected via screw terminal

2.4 Analogue interface connection

See section „5.9 The analogue interface“.

3. Functional description

3.1 Battery types

The battery chargers can be used to charge different types of lead batteries, as for example lead-acid, gel cell or AGM type. Any of the battery types are charged according to a three-stage, temperature compensating (only with temperature sensor connected) charging procedure. The battery type can be selected by a push-button on the front panel. The related charging profiles mainly differ in the cell voltage (see table below).

3.2 Charging procedure

Attention! Defective batteries ($U_{BatAct} = <0.4 \times U_{BatNom}$) can not be charged!

The charging procedure follows an I-U-U characteristics.

In the first phase of the charging the battery is **precharged** with reduced output current ($0.1 \times I_{Nom}$). The precharge is very effective on deeply discharged batteries with $U_{BatAct} = >0.4 \times U_{BatNom}$, providing the possibility to repair and recharge them again. As soon as the output voltage rises to $0.9 \times U_{BatNom}$ or after a maximum precharge time of **30 minutes**, the procedure changes to **normal charge** phase. Precharge and normal charge are indicated by the red LED of the traffic light type display.

During normal charge, the battery is charged with full output current I_{Nom} (or with a reduced to 30% output current I-Limit).

After leaving the constant current charging or after a maximum **6 hours** charging time, the charging procedure changes to **boost charge** (yellow LED).

Boost charge is done with increased charging voltage. As soon as the charging current becomes $<5\%$ of I_{Nom} or the boost charge phase time exceeds **1.5 times** the time of the normal charge phase, the charging procedure changes to **trickle charge**.

When reached and if the charging current remains below $5\% I_{Nom}$, the battery is indicated as fully charged by the green status LED.

During trickle charge, the battery is kept charged with trickle charge voltage for an unlimited time, unless charging is stopped or interrupted by any error or blackout.

Boost charge and **trickle charge** make use the temperature compensation, which is recommend in order to prevent the batteries from gassing.

Tip: it is possible to manually reduce the output current by activating the 30% I-Limit. This is done by pressing the pushbutton „Charging Profiles“ longer than 3s.

The I-Limit is useful when charging small batteries that require lower charging currents.

3.2.1 Charging characteristics

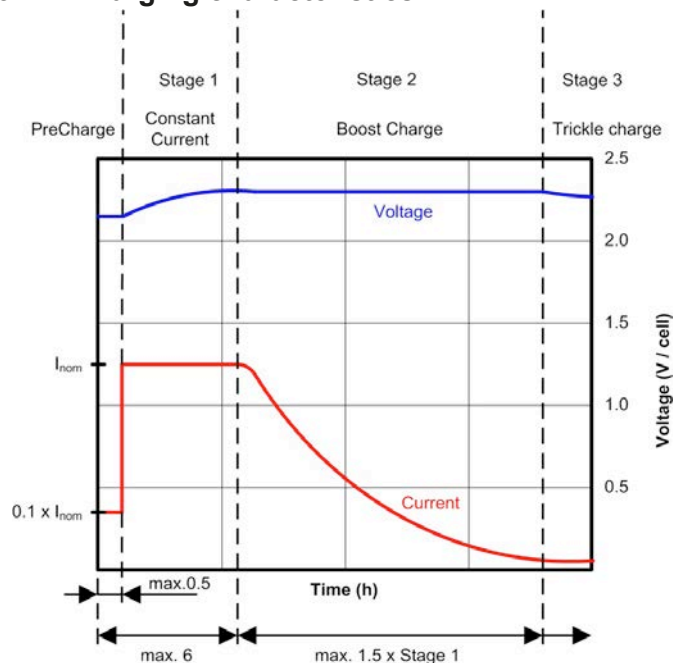

3.3 Battery supervision

The battery or batteries are connected to the designated terminal „Battery“ on the front. The output is supervised for false polarity and wrong battery voltage. In case the battery was connected with false polarity, the battery voltage is too low or too high, the charging is inhibited to start.

Attention! Only connect batteries whose battery voltage matches the nominal charging voltage of the device. Else the battery and/or the device might get damaged.

3.4 Temperature sensor

It is recommended to use temperature compensation when charging batteries, in order to prevent dangerous gassing.

Without the temperature sensor the batteries are charged with voltages that correspond to an ambient temperature of 25°C . The sensor is directly connected to pins 1 and 6 of the analogue interface and has to be placed in proximity of the battery or attached to the battery. It is detected and used when the charging is started. If the device measures temperatures above $+50^{\circ}\text{C}$, the charging is paused. After cooling down to $<+45^{\circ}\text{C}$, the charging is automatically continued. This only works if the temperature sensor is attached. The error LED will only flash as long the battery overtemperature error persists.

At temperatures below -15°C , the temperature compensation will halt. In case the sensor is removed during charging or if damaged, the device continues the charging procedure with a charge phase voltage corresponding to 25°C .

In order for the user to notice temperature related errors, the LED keeps flashing even if the temperature is within the normal range again. Starting the charging again or switching to power supply mode will erase the error and LED will stop flashing, if the temperature is OK.

Temperature sensors of type LM335 or similar, which are specified with 10mV/K temperature voltage, can be used. Pin 1 delivers approx. 4.1V and currents from 0.8mA (internal 1k in series to the temp sensor).

The temperature compensation of the charging voltage is done with 4mV/°C and per battery cell.

3.5 Remote sense

In order to compensate voltage drops along the load leads, the device features remote sense inputs on the front. Here the sensed voltage from the battery is connected with correct polarity. Remote sense can compensate up to 2V.

When not using the sense inputs, they just remain open. It is not required to bridge them to the output.

The cross section of the sense leads is non-critical.

3.6 Power supply mode

The device can be used as power supply, if „Power Supply Mode“ has been selected with the „Charging profiles“ button. In this mode, the output voltage can then be adjusted with the trimmer within a limited range (see „4. Technical specifications“). It either works in constant voltage or in constant current operation (U-I characteristics), displayed by the green or red LED on the front panel.

This mode is suitable for parallel standby operation, also see „5.7 Parallel standby operation“.

3.7 Overvoltage protection (OVP)

All models feature an overvoltage protection circuit. In case of an overvoltage condition, whether caused by an internal defect or by external reasons, the power output is switched off and the error is indicated by flashing LED „Error“ and also by pin 9 of the analogue interface. After the OV condition is gone, the output can be switched on resp. the charging can be started again.

3.8 Overtemperature (OT)

All models also feature an internal temperature supervision. In case of overheating, the power output will be temporarily switched off until the device has cooled down, and then automatically switch on again.

Charging is thus only interrupted, but not stopped. The condition is indicated by flashing LED „Error“ and by pin 9 of the analogue interface.

3.9 Errors

Any error is indicated by flashing LED „Error“. Following general errors can be signaled:

- Overvoltage (OVP)
- Overtemperature (OT)
- Battery connected with false polarity

The errors OVP and OT are also indicated at the analogue interface.

In battery charger mode, i.e. not in power supply mode, following additional errors can be signaled:

- Connection of battery with too low or too high voltage
- Temperature sensor failure (broken wire etc.)

3.10 Remote control

All models feature a 12 pin analogue interface on the front of the device. It can be used to monitor the device condition, as well as remotely start/stop the charging procedure. Also see section 5.9 and up.

3.11 Automatic charging mode

This extra mode can be activated to start charging of batteries automatically after mains supply is switched on or if a battery is connected. For details see „5.10 Activate automatic charging mode“.

4. Technical specifications

	BC 812-20R	BC 824-10R	BC 848-05R	BC 812-40R	BC 824-20R	BC 848-10R
Mains input						
Input voltage	90...264V	90...264V	90...264V	90...264V	90...264V	90...264V
Frequency	45...65Hz	45...65Hz	45...65Hz	45...65Hz	45...65Hz	45...65Hz
Power factor correction	>0.99	>0.99	>0.99	>0.99	>0.99	>0.99
Input current at 230V	1.6A	1.6A	1.6A	3.4A	3.2A	3.2A
Fuse	M6.3A	M6.3A	M6.3A	T10A	T10A	T10A
Output - Voltage						
Battery voltage U_{Bat}	12V	24V	48V	12V	24V	48V
Adjustable range	10...15V	20...30V	40...60V	10...15V	20...30V	40...60V
Stability at 10-90% load	<0.05%	<0.05%	<0.05%	<0.05%	<0.05%	<0.05%
Stability at $\pm 10\% \Delta U_{in}$	<0.02%	<0.02%	<0.02%	<0.02%	<0.02%	<0.02%
Ripple	<40mV _{PP}	<100mV _{PP}	<150mV _{PP}	<10mV _{PP}	<100mV _{PP}	<150mV _{PP}
Regulation 10-100% load	<2ms	<2ms	<2ms	<2ms	<2ms	<2ms
Output - Current						
Nominal current	20A	10A	5A	40A	20A	10A
Stability at 0-100% ΔU_{out}	<0.15%	<0.15%	<0.15%	<0.15%	<0.15%	<0.15%
Stability at $\pm 10\% \Delta U_{in}$	<0.05%	<0.05%	<0.05%	<0.05%	<0.05%	<0.05%
Ripple	<60mA _{PP}	<35mA _{PP}	<12mA _{PP}	<19mA _{PP}	<65mA _{PP}	<25mA _{PP}
Output - Power						
Nominal power	300W	300W	300W	600W	600W	600W
Miscellaneous						
Operation temperature	0...50°C	0...50°C	0...50°C	0...50°C	0...50°C	0...50°C
Storage temperature	-20...70°C	-20...70°C	-20...70°C	-20...70°C	-20...70°C	-20...70°C
Humidity	<80%	<80%	<80%	<80%	<80%	<80%
Dimensions (WxHxD)	218x83x163mm	218x83x163mm	218x83x163mm	90x360x240mm	218x83x163mm	218x83x163mm
Weight	2.2kg	2.2kg	2.2kg	6.5kg	2.2kg	2.2kg
Article No.	27150311	27150312	27150313	27150316	27150314	27150315
Safety	EN 60950					
EMC standards	EN 61326, EN 550022 Class B					
Overvoltage category	Class II					
Protection class	Class I					

4.1 Dimensional drawings

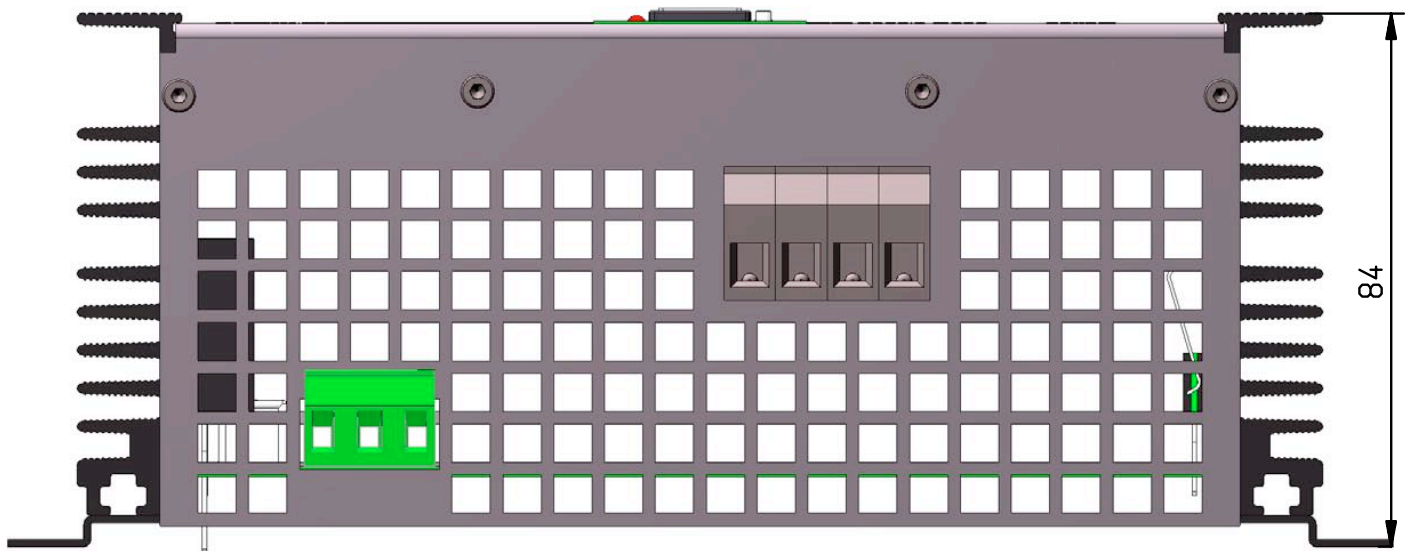
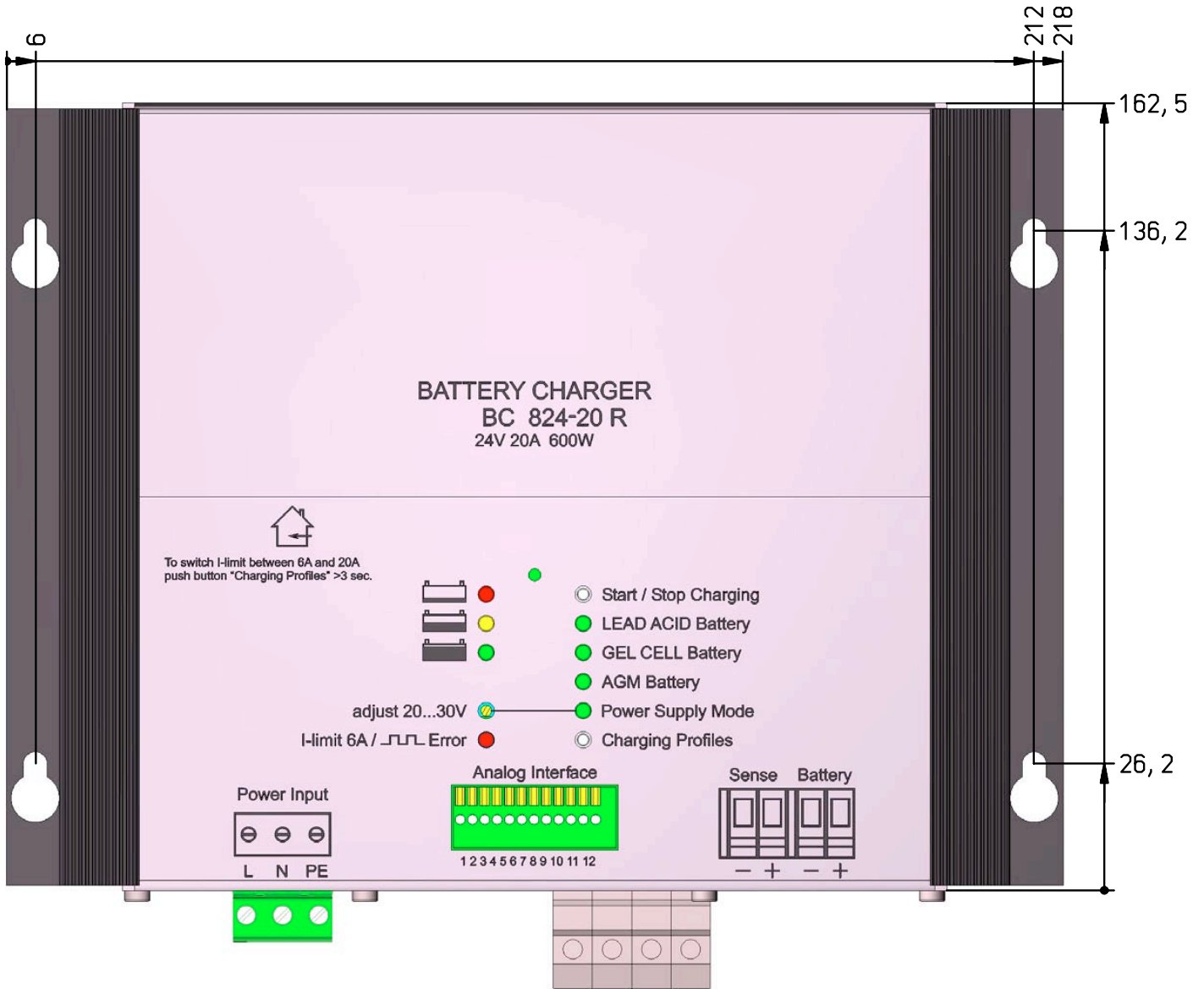

Housing type 1: Models up to 20A

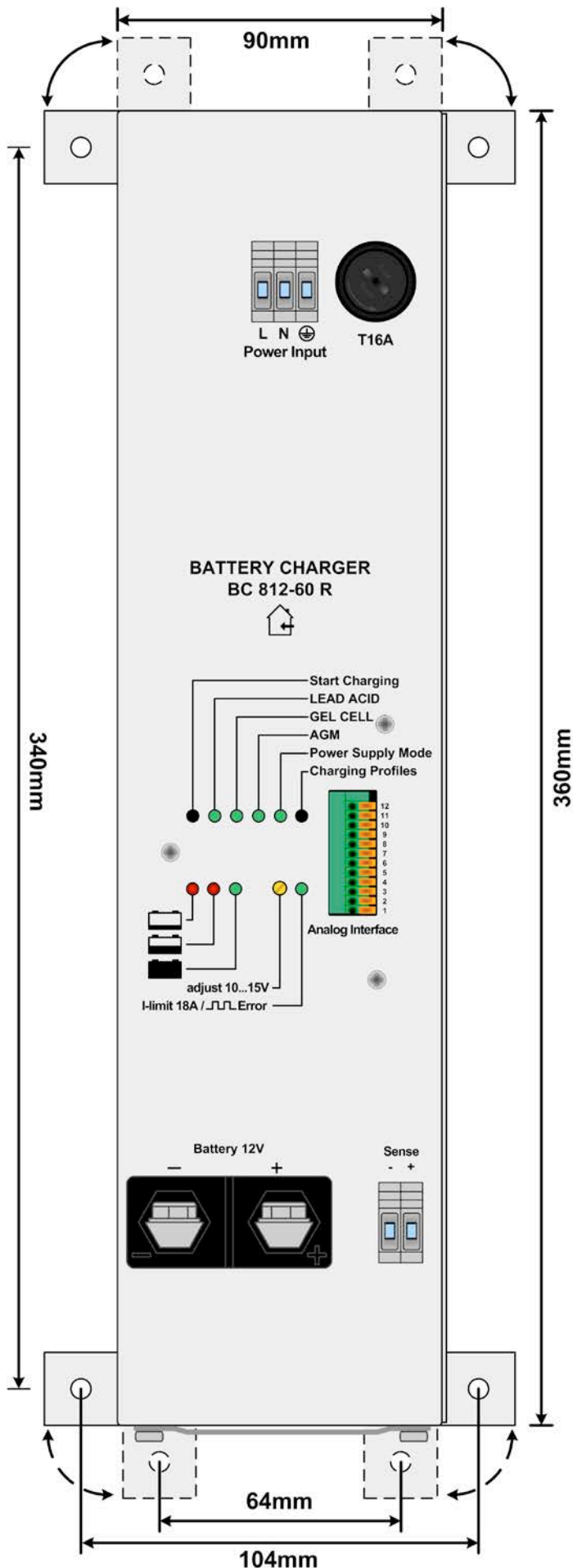

Housing type 2, as used for BC 812-40 R

5. Handling

5.1 Powering the device

The device does not feature a power switch. When connecting it to mains, it is immediately ready to work.

After switching mains off, the device stores the last state (selected mode, output condition, charging condition) in order to restore it automatically after the next start. Thus it can continue to work after an interruption like a blackout etc. It means, it will continue to charge the battery, as long as the condition hasn't changed (different battery with wrong voltage or false polarity, battery temperature error, no battery connected).

5.2 Connecting batteries

The battery charger only allows to charge batteries that meet the device's specifications regarding output voltage. The maximum charging current I_{Nom} or 30% of I_{Nom} , if „I-Limit“ has been activated. The maximum charging voltage is about 2.43V/cell (depends on battery model), plus temperature compensation.

The cross section of the battery leads has to be according to the nominal current of the battery charger.

Attention! Before connecting or disconnecting batteries it is imperative to check if charging has been stopped. No LED may be lit next to battery level symbols printed on the front plate.

5.3 Selecting a battery profile

In order to select the battery profile before starting a charging, the output has to be off. The pushbutton „Charging Profiles“ selects one out of three charging profiles, all for **lead batteries**. A LED indicates the selected type.

The selected charging profile considers battery-specific cell voltages, that are given by the battery producers:

	Normal charge	Boost charge	Trickle charge
Lead Acid	2V/Cell	2.38V/Cell	2.28V/Cell
Lead Gel	2V/Cell	2.40V/Cell	2.28V/Cell
Lead AGM	2V/Cell	2.43V/Cell	2.28V/Cell

5.4 Start charging

The charging can be started by pressing the pushbutton „Start / Stop Charging“ or by using pin 8 of the analogue interface. Following errors will prevent the start:

- No battery connected
- Battery voltage too low (LED flashes)
- Battery voltage too high (LED flashes)
- Battery temperature too high (LED flashes)(only with connected temperature sensor)
- Battery connected with false polarity (LED flashes)

The battery is charged according to the selected battery profile and according to the charging characteristics depicted in the figure in section „Charging procedure“. The currently active stage of the charging is indicated by one of the three LEDs next to the battery level symbols on the front (traffic light).

The charging procedure is also indicated by the signal „Charging“ on the analogue interface.

Note: immediate start, after the last charging has been stopped manually, is only possible after >30s. This also applies for a longer mains blackout or manual switch-off. Short mains blackouts (<5s) are compensated by device itself, while pausing the charging procedure.

5.5 Stop charging

The pushbutton „Start / Stop Charging“ or pin 8 of the analogue interface are used to stop the charging immediately at any phase. The output will then be switched off and no LED next to the battery charging level symbols will be lit anymore.

Before connecting or disconnecting the battery the charging must be stopped!

5.6 Charging with reduced current

Batteries with small capacity can be charged with reduced charging phase current (30% of normal phase current) by activating the „I-Limit“ feature.

The maximum value of the reduced charging current is stated on the front plate as „I-limit xA“ (next to LED „Error“). The LED „I-Limit 30%“ indicates the activated current limitation by being permanently on (as long as no error is present).

The feature can be activated anytime by pressing the pushbutton „Charging Profiles“ for longer than 3 seconds.

5.7 Parallel standby operation

Note: only the selection „Power Supply Mode“ is suitable for parallel standby operation.

The battery charger can be operated in parallel standby operation during power supply mode (see section 5.8) and together with another charger being in charger mode, in order to reproduce the behaviour of an UPS.

5.8 Power Supply Mode

The battery charger can be used as a power supply with limited voltage adjustment range. To select the „Power Supply Mode“, use pushbutton „Charging Profiles“ while the output is switched off.

Switching the power output on or off is done by pressing the button „Start / Stop Charging“.

While the output is on, the green status LED indicates constant voltage (CV, green) operation or the red status LED indicates constant current (CC, red) operation:

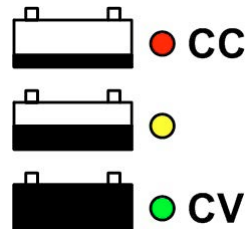

Both operation modes depend on the voltage/current condition on the output.

The output current is limited to the device's nominal current and can't be adjusted.

In order to adjust the output voltage with the trimmer within the given range the output has to be switched on.

Connecting a load should only be done while the output is switched off. The cross section of the load leads must match the nominal current of the device.

Note: in „Power Supply Mode“, the device also indicates a battery connected with false polarity by flashing the error LED.

Note: the manually switchable current limitation I-Limit can reduce the output current to 30% also in this mode.

5.9 The analogue interface

The analogue interface allows to monitor the device's output values (voltage and current) and the condition (errors) remotely. It can also start or stop a charging.

The monitor outputs represent with 0...10V the nominal values of the device from 0...100%.

The temperature sensor is also connected to the analogue interface. The clamps are suitable for 20 - 26 AWG wires, dismantled at least 10mm.

See the table on the previous page for pin assignment and levels.

Attention! Do not connect anything to pins 11 and 12.

In order to remotely start or stop a charging procedure, the device has to be switched to remote control by pulling pin 7 to low. Also see the examples below.

Note: Using the digital inputs „Remote“ or „REM-SB“ requires to use a low-resistive contact (switch, relay, open collector transistor). A digital output of a control application like a PLC might not be sufficient here. Please consult the technical documentation of your control application first.

5.9.1 Connection

The 12 pole analogue interface on the top side is of type press & clamp. It is eligible for cable cross sections of 0.1mm² (26 AWG) to 0.5mm² (20 AWG). If possible, use cable end sleeves.

Clamping procedure:

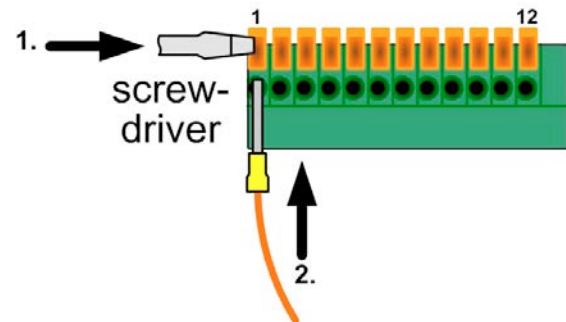

5.9.2 Pin assignment

Pin	Name	Type ¹	Description	Level	Electrical specifications
1	Temp sensor	AO	Temperature sensor	LM 335	10mV/°K
2	Trickle / Battery full	AO	Trickle charge / Charging done	Charging done = High ($U_{High} > 4V$), else = Low ($U_{Low} < 1V$)	$U_{max} = 30V$, $I_{max} = -20mA$ Quasi Open Collector with 10k pull-up to V_{cc} ⁽²⁾
3	Charging	AO	Charging active	Charging = High ($U_{High} > 4V$), else = Low ($U_{Low} < 1V$)	
4	VMON	AO	Actual value: voltage	0...10V corresponds to 0...100% of U_{Nom}	Accuracy 0.1% at $I_{max} = +2mA$ Short-circuit-proof against AGND
5	CMON	AO	Actual value: current	0...10V corresponds to 0...100% of I_{Nom}	
6	AGND		Reference for analogue signals		For CMON, VMON
7	Remote	AI	Activate remote control	External = Low ($U_{Low} < 1V$), Internal = High ($U_{High} > 4V$)	$U_{max} = 30V$ $I_{max} = -1mA$ at 5V
8	Start / Stop	AI	PS mode: Power output off Bat mode: Start/Stop charging	Off / Start = Low ($U_{Low} < 1V$), On / Stop = High ($U_{High} > 4V$)	
9	OT / OVP	AO	Overtemperature OT / Overvoltage OVP	Low = No error ($U_{Low} < 1V$) High = Error ($U_{High} > 4V$)	$U_{max} = 30V$, $I_{max} = -20mA$ Quasi Open Collector with 10k pull-up to V_{cc} ⁽²⁾
10	DGND		Reference for digital signals		For control and monitoring signals
11	Reserved	X	must not be connected		
12	Reserved	X	must not be connected		

¹⁾ AO = Analogue output, AI = analogue input

²⁾ 12V...15V

5.9.3 Example applications

I. Charging start/stop (output on/off)

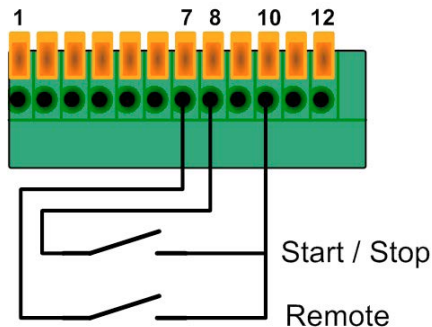

Before the **charging** can be started remotely, the device is required to be set into remote control (pin 7).

In battery charging mode the pin is used to start or stop the charging.

In „Power Supply Mode“, pin 8 is used to switch the power output off and then on again. In this mode, the output can be used whether the remote control is active or not, like an emergency off switch.

Reference is digital ground (DGND).

Caution! If pin „Start/Stop“ is already pulled to LOW when switching to remote control, then the charging will start immediately.

II. Monitoring the device condition

The outputs are quasi open collector outputs with a 10k pull-up resistor to Vcc. They work as current sinks. The maximum input voltage must not exceed 30V and the maximum input current must not exceed 20mA.

With this, also relays or LEDs can be used to indicate the status without the necessity to amplify.

Note, that the pins are HIGH when indicating their dedicated signal. It might be required to invert them when used to switch a relay or a LED.

Reference is digital ground (DGND).

III. Monitoring voltage and current

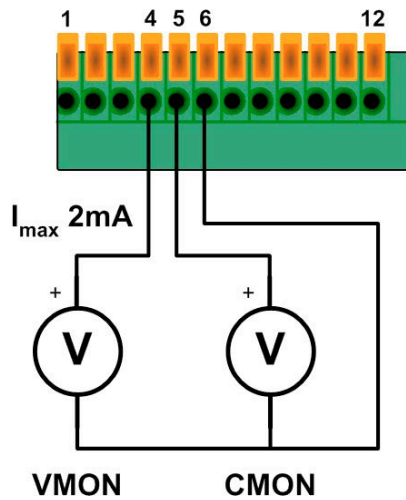

The analogue monitoring outputs put out 0...10V which corresponds to 0...100% of the nominal values.

Reference is analogue ground (AGND).

IV. Temperature sensor input

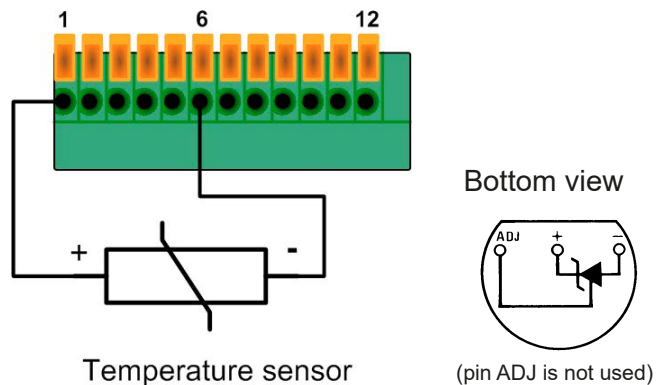

The temperature sensor alters the charging voltage according to the ambient temperature of the battery, if placed in proximity, or to the battery surface temperature if placed directly on the battery.

It is important to only use sensors with 10mV/K. Allowed temperature range for charging is -15°C...50°C.

The included sensor is a LM335, pin assignment as shown above. Always connect with correct polarity according to the wiring scheme.

5.10 Activate automatic charging mode

Note: the automatic charging mode requires switching the device to remote control. No manual control possible during remote control. It means, in case the current limitation „I-Limit“ is going to be used, it must be activated before. The battery type (LEAD ACID etc.) also has to be selected before.

Automatic charging means

- a) the charging will automatically start after the mains supply is switched on, but only if a battery is connected and no error is present
- b) the charging will automatically start as soon as a battery is connected to the running charger, but only if no error is present.

In order to activate this mode, it is required to set bridges on the analogue interface, which also could be replaced by switches if manual switching is favored. Using bridges, the charging procedure can not be stopped manually.

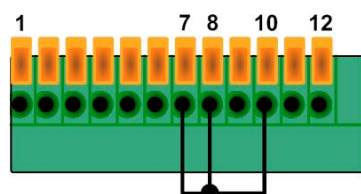

Automatic

If the charging is done (green LED of traffic light), another battery can be charged.

Attention! In case a the load is connected to the battery in parallel it may draw current from the charger. A high current consumption is considered as an empty battery by the charger and it will change to boost or precharge mode again, altering the output voltage.

6. Miscellaneous

6.1 Resetting the control panel

In the rare case the device will not respond to manual control, the control can be reset. This is done by pressing and holding pushbutton „Charging profiles“ while the device is powered on. This will reset following:

- Output off
- Power Supply Mode selected
- I-Limit activated



Elektro-Automatik

EA-Elektro-Automatik GmbH & Co. KG

开发 - 生产 - 销售一体化
Development - Production - Sales

Helmholtzstraße 31-37
41747 Viersen
Germany

Tel: +49 2162 / 37 85-0
Fax: +49 2162 / 16 230
ea1974@elektroautomatik.cn
www.elektroautomatik.cn